

NOTE: \*ESTIMATED DIMENSIONS.  
MEASUREMENTS DEPEND ON CHASSIS,  
TIRES, SPRINGS, AND LOADING.

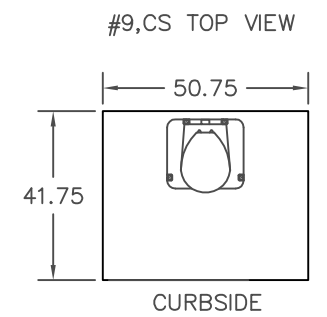
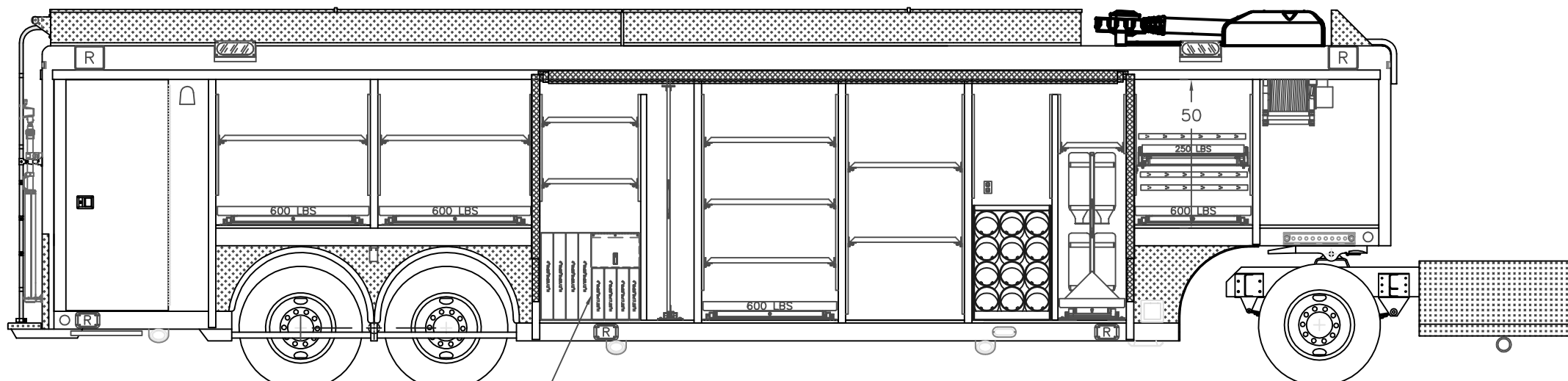
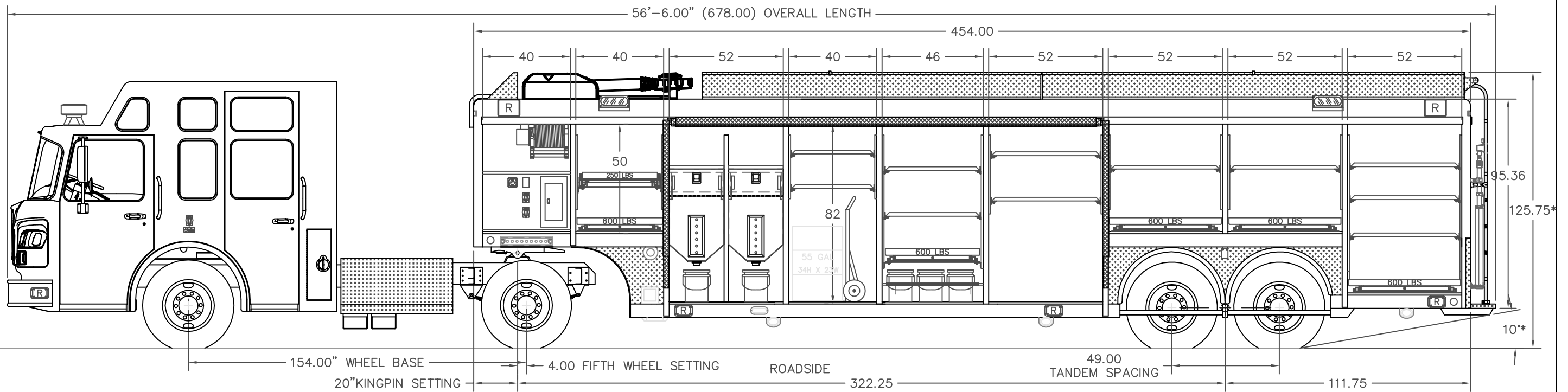

CURBSIDE  
AIR BAG STORAGE TO BE SHIPPED LOOSE

DATE	SYM	REVISION RECORD	AUTH	DRFT.
UNLESS OTHERWISE SPECIFIED				
DIMENSIONS ARE IN INCHES				
TOLERANCES ON:				
2 PL. DECIMALS ±				
3 PL. DECIMALS ±				
ANGLES ±				
FRACTIONS ±				
DRAWN BY	DATE	MODEL: TC1882 CJEKTOWAGA, NY		
KMB	12/18/06	3-EST-18	RTX	82/50
APPROVED BY	DATE	SCALE		
		1=34	D-06C-792	
SUPERSEDES	SUPERSEDED BY			

CUSTOM DESIGNED FOR:  
07F09220  
ERIE COUNTY EMERGENCY SERVICES  
CHEEKTOWAGA, NY

THIS PRINT AND ALL RIGHTS TO THE DESIGN AND DETAIL THEREON ARE THE PROPERTY OF HACKNEY & SONS, INC., WASHINGTON, N.C. AND IS LOANED TO THE RECIPIENT SUBJECT TO RETURN UPON DEMAND. ITS CONTENTS ARE CONFIDENTIAL AND MUST NOT BE COPIED OR SUBMITTED TO OUTSIDE PARTIES FOR USE OR EXAMINATION.  
© 2006 HACKNEY, A DIVISION OF SVC