

NOTE: *ESTIMATED DIMENSIONS.
MEASUREMENTS DEPEND ON CHASSIS,
TIRES, SPRINGS, AND LOADING.

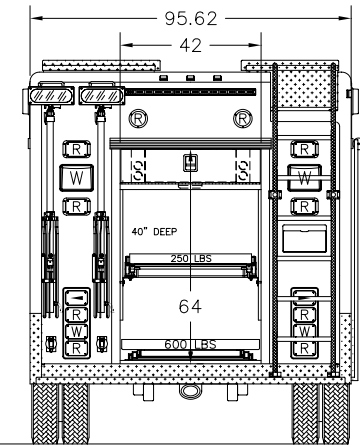

REAR VIEW

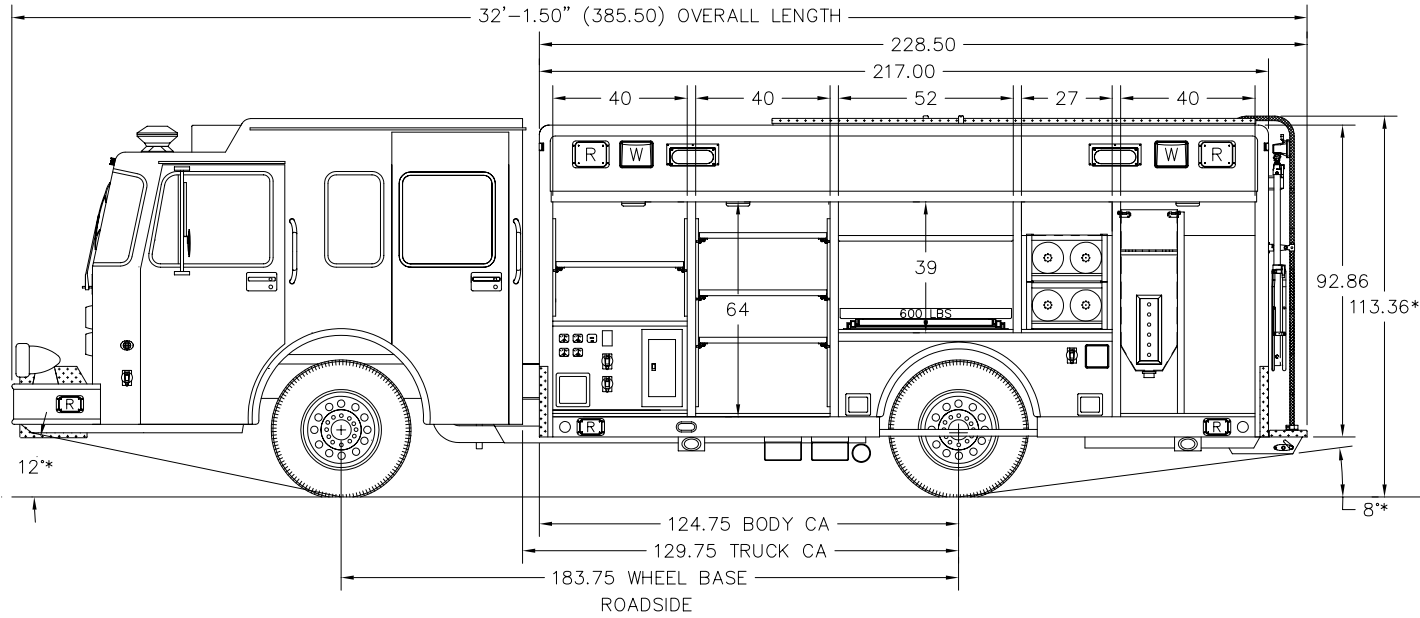
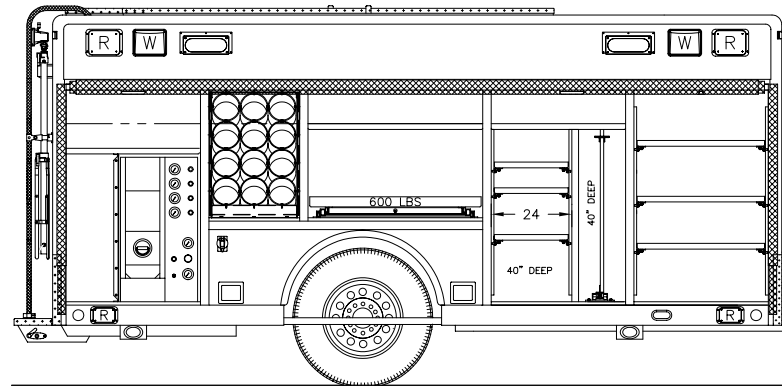

CURBSIDE

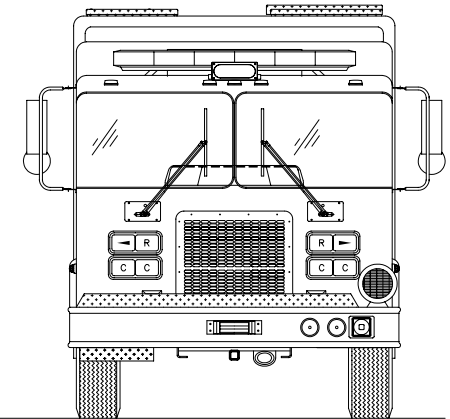

THIS PRINT AND ALL RIGHTS TO THE DESIGN AND DETAIL THEREON ARE THE PROPERTY OF HACKNEY & SONS, INC., WASHINGTON, N.C. AND IS LOANED TO THE RECIPIENT SUBJECT TO RETURN UPON DEMAND. ITS CONTENTS ARE CONFIDENTIAL AND MUST NOT BE COPIED OR SUBMITTED TO OUTSIDE PARTIES FOR USE OR EXAMINATION.

© 2003 HACKNEY, A DIVISION OF SVC

CUSTOM DESIGNED FOR:
#05F09017
SLOOP POINT FIRE DEPARTMENT
HAMPSTEAD, NC

DATE	SYM	REVISION RECORD		AUTH	DRFT.
UNLESS OTHERWISE SPECIFIED					
DIMENSIONS ARE IN INCHES					
TOLERANCES ON:					
2 PL. DECIMALS ±					
3 PL. DECIMALS ±					
ANGLES ±					
FRACTIONS ±					
DRAWN BY	DATE	EMERGENCY VEHICLES		EMERGENCY VEHICLES DIVISION	
TLB	07/14/04	3-ESV-11 RTX 64/39		WASHINGTON, NC 27889-0880	
APPROVED BY	DATE	MODEL: DFC1164R		HAMPSTEAD, NC	
SUPERSEDES	SUPERSEDED BY	SCALE	1=30		
			D-04C-306		