

REFER TO DRAWING D-07C-088C FOR CURBSIDE (RIGHT) VIEW.
 REFER TO DRAWING D-07C-089C FOR FRONT AND REAR VIEWS.
 REFER TO DRAWING D-07C-090B FOR TOP PLAN VIEW.

NOTE: *ESTIMATED DIMENSIONS.
 MEASUREMENTS DEPEND ON CHASSIS,
 TIRES, SPRINGS, AND LOADING.

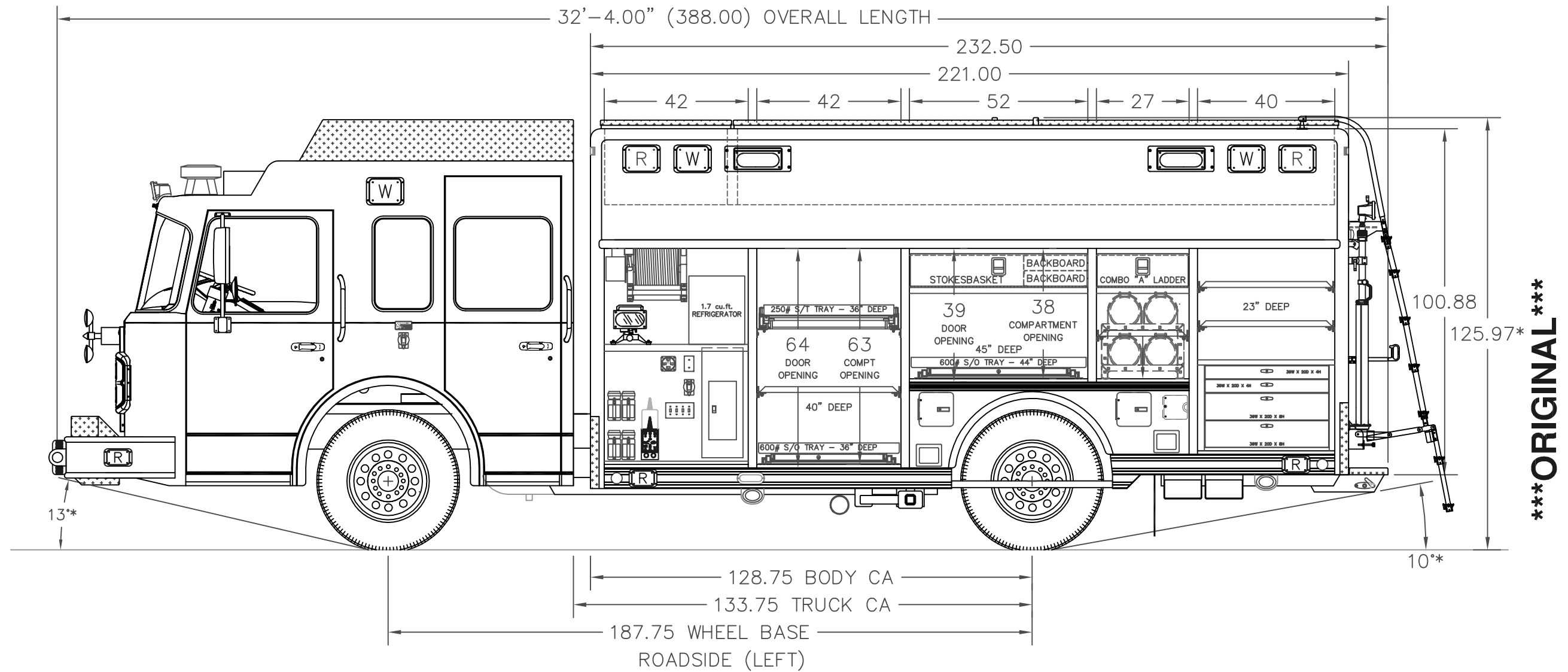

*** ORIGINAL ***

CUSTOM DESIGNED FOR:
 #08F09291
 CONNESTEE FIRE & RESCUE, INC.
 BREVARD, NC

THIS PRINT AND ALL RIGHTS TO THE DESIGN AND DETAIL THEREON ARE THE PROPERTY OF HACKNEY, WASHINGTON, N.C. AND IS LOANED TO THE RECIPIENT SUBJECT TO RETURN UPON DEMAND. ITS CONTENTS ARE CONFIDENTIAL AND MUST NOT BE COPIED OR SUBMITTED TO OUTSIDE PARTIES FOR USE OR EXAMINATION.

© 2007 HACKNEY
 A Division of VT SVC

07-08-08	C	REV PER CUSTOMER CHANGE REQUEST	AND	UNLESS OTHERWISE SPECIFIED DIMENSIONS ARE IN INCHES TOLERANCES ON: 2 PL. DECIMALS ± 3 PL. DECIMALS ± ANGLES ± FRACTIONS ±		EMERGENCY VEHICLES DIVISION WASHINGTON, NC 27889-0880
05-20-08	B	REV PER CUSTOMER CHANGE REQUEST	AND	DRAWN BY AND DATE 02-12-07		3-ESV-11 RTX 64/39
04-01-08	A	REV PER CUSTOMER CHANGE REQUEST	AND	APPROVED BY DATE	MODEL: DFC1164R	BREVARD, NC
DATE	SYM	REVISION RECORD	AUTH DRFT.	SUPERSEDES	SUPERSEDED BY	SCALE 1=24

D-07C-087C

REFER TO DRAWING D-07C-087C FOR ROADSIDE (LEFT) VIEW.
 REFER TO DRAWING D-07C-088C FOR CURBSIDE (RIGHT) VIEW.
 REFER TO DRAWING D-07C-090C FOR TOP PLAN VIEW.

NOTE: *ESTIMATED DIMENSIONS.
 MEASUREMENTS DEPEND ON CHASSIS,
 TIRES, SPRINGS, AND LOADING.

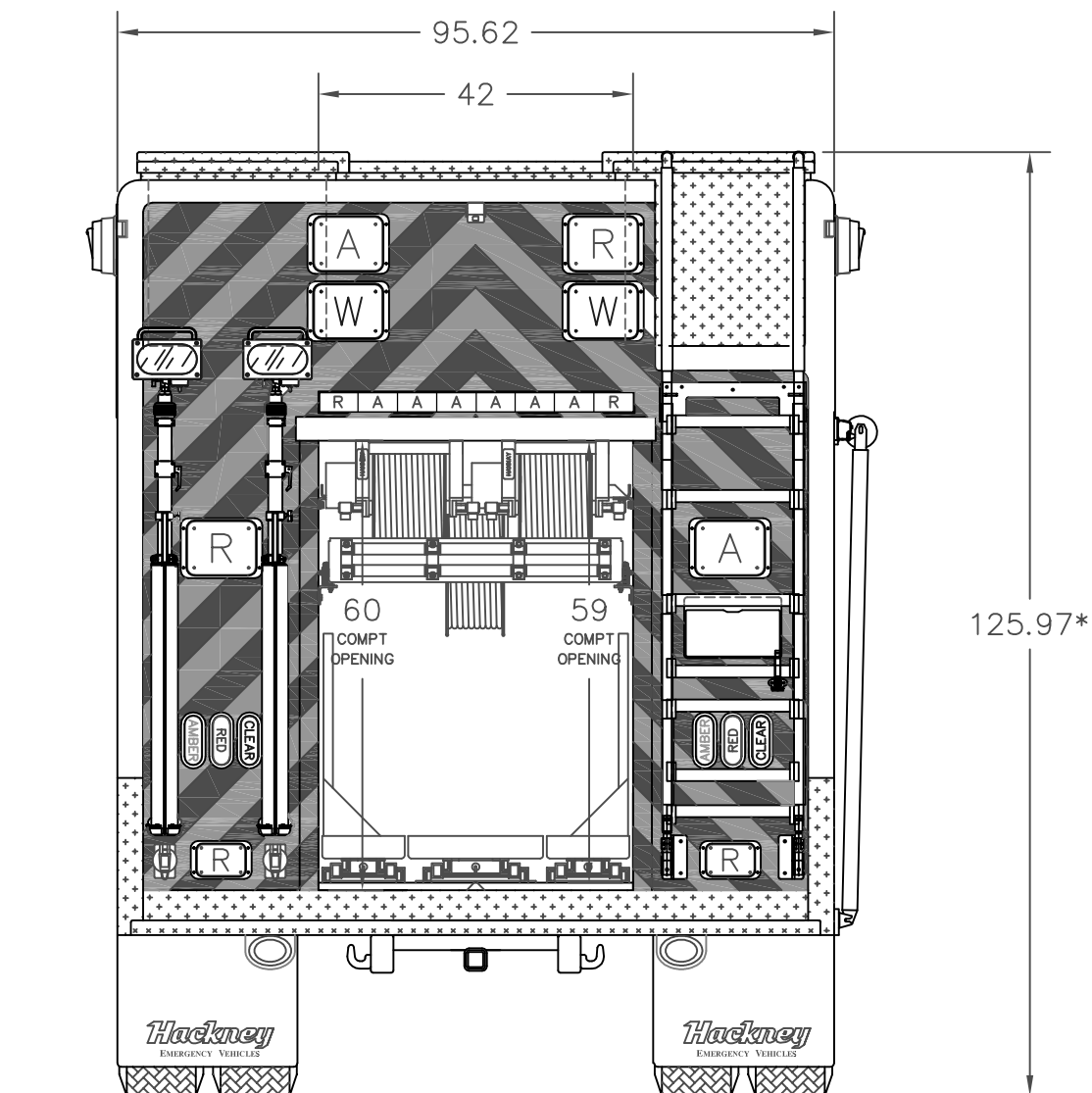

REAR VIEW

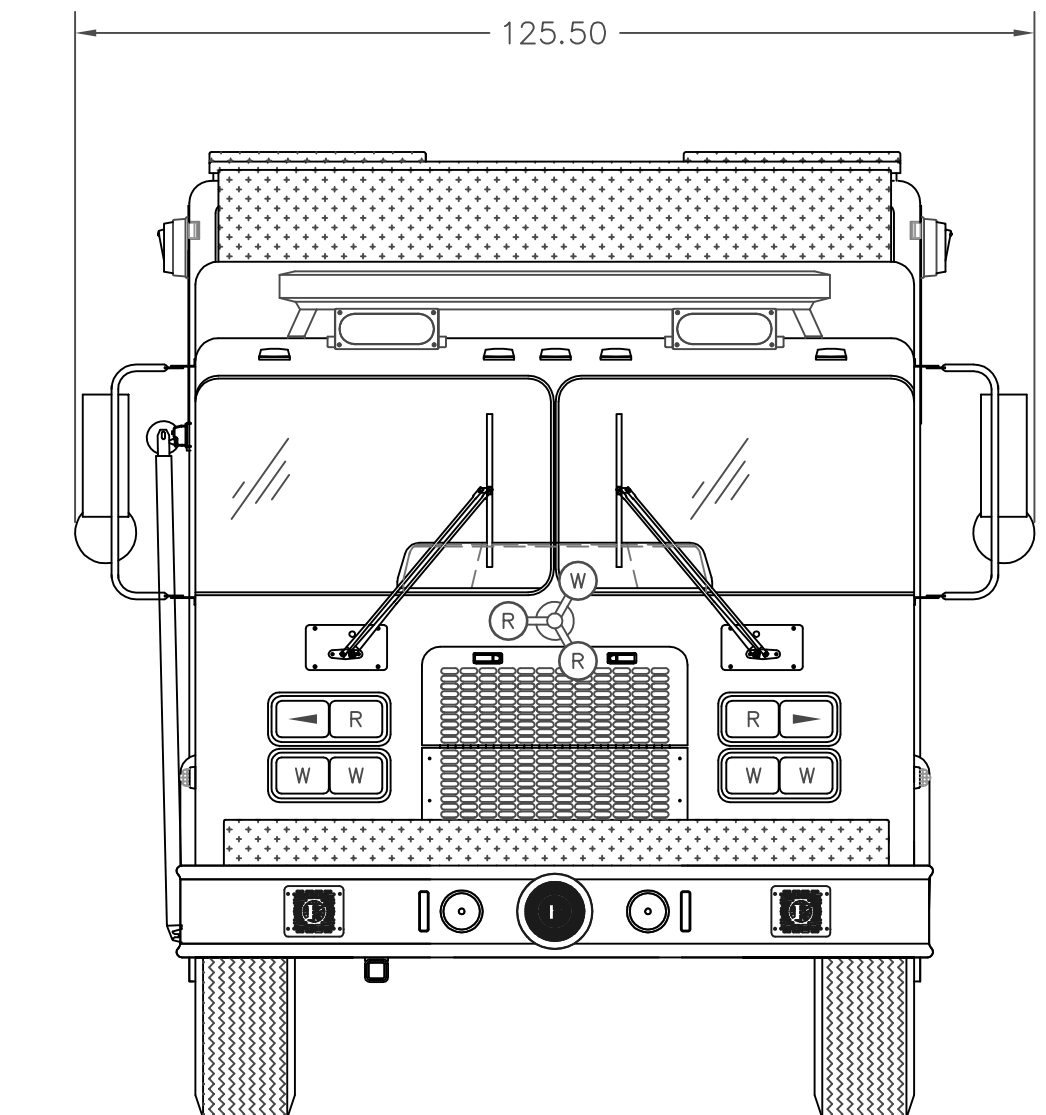

FRONT VIEW

ORIGINAL

CUSTOM DESIGNED FOR:
 #08F09291
 CONNESTEE FIRE & RESCUE, INC.
 BREVARD, NC

THIS PRINT AND ALL RIGHTS TO THE DESIGN AND DETAIL THEREON ARE THE PROPERTY OF HACKNEY, WASHINGTON, N.C. AND IS LOANED TO THE RECIPIENT SUBJECT TO RETURN UPON DEMAND. ITS CONTENTS ARE CONFIDENTIAL AND MUST NOT BE COPIED OR SUBMITTED TO OUTSIDE PARTIES FOR USE OR EXAMINATION.

© 2007 HACKNEY
 A Division of VT SVC

07-21-08	C	REV PER CUSTOMER CHANGE REQUEST	AND	UNLESS OTHERWISE SPECIFIED DIMENSIONS ARE IN INCHES TOLERANCES ON: 2 PL. DECIMALS ± 3 PL. DECIMALS ± ANGLES ± FRACTIONS ±		EMERGENCY VEHICLES DIVISION WASHINGTON, NC 27889-0880
05-30-08	B	REV PER CUSTOMER CHANGE REQUEST	AND	DRAWN BY AND DATE 02-12-07		
04-01-08	A	REV PER CUSTOMER CHANGE REQUEST	AND	APPROVED BY DATE	3-ESV-11	RTX 64/39
DATE	SYM	REVISION RECORD	AUTH DRFT.	SUPERSEDES	SUPERSEDED BY	SCALE
						1=24
						D-07C-089C